

**English SS341A**

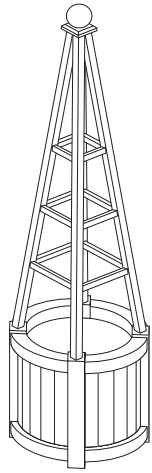

**Before assembly**

- We recommend that time is taken to read the instructions before starting assembly, then follow the easy step by step guide. The instruction sheet is only a guide to the assembly. Certain items may not be shown to scale.
- Check all components prior to assembly
- This product should be assembled by no less than two people.
- Never attempt to erect the assembly in high winds.
- It may be necessary to drill pilot holes for each screw.

**Biocidal Products Regulation EU 528/2012**  
Wolmanit® CX treated wood is a treated article that incorporates biocidal products: copper hydroxide carbonate/II/ and boric acid. They protect wood against fungal decay /rot/ and insect attack.  
Keep away from food, drink and animal feeding stuffs. Avoid breathing dust when cutting treated wood.



**Recommended tools for assembly**

- Power screwdriver
- Cross head screwdriver bit

No.	Components	Qty.
1	Planter base	1
2	Obelisk legs	4
3	Obelisk frame (220mm)	4
4	Obelisk frame (160mm)	4
5	Obelisk frame (100mm)	4
6	Cap	1
7	Finial	1

No.	Components	Qty.
8	L-bracket	4
9	50mm screws	16
10	40mm screws	12
11	16mm screws	8
12	Planter liner material	1

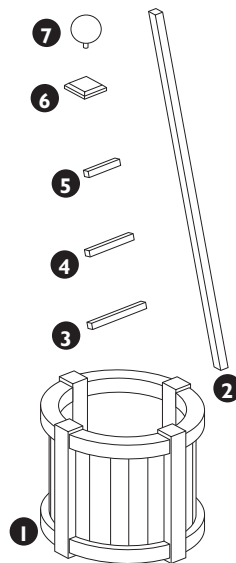

**1. Obelisk legs and frame**

Secure two legs together using one of each length frame as shown below. Secure the longer length frame at the bottom through the pre-drilled holes using 2 x 50mm screws. The middle and top frames are secured through the pre-drilled holes using 2 x 40mm for each frame. Create a second structure in the same way.

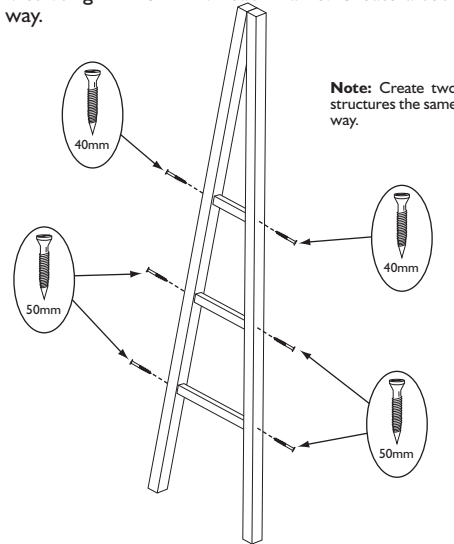

**2. Join the two leg sections**

Join the two leg sections as shown below. Secure the longer length frames at the bottom through the pre-drilled holes using 2 x 50mm screws per frame. The middle and top frames are secured through the pre-drilled holes using 2 x 40mm for each frame.

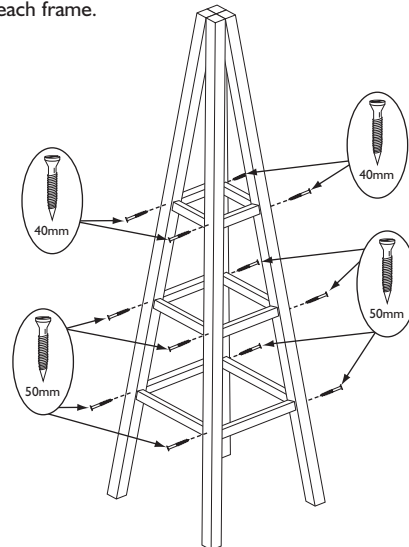

**3. Cap and finial**

Screw the cap to the top of the legs through the pre-drilled holes using 4 x 40mm screws. Align the dowel on the ball finial with the hole in the centre of the cap and push it firmly into place.

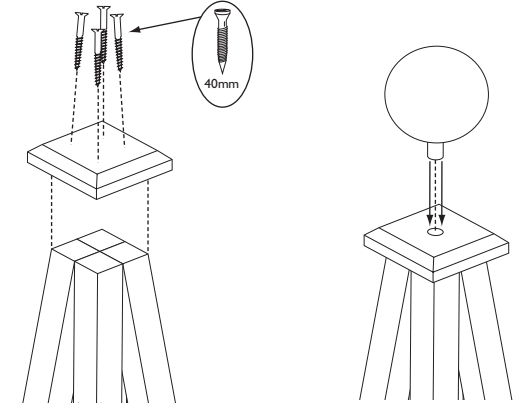

**4. Secure obelisk to planter base**

Position the obelisk onto the planter base, position an L-bracket under each of the legs and carefully remove the obelisk. Secure each bracket to the base using 1 x 16mm screw per bracket. Replace the obelisk and secure the brackets to the obelisk using 1 x 16mm screw per bracket.

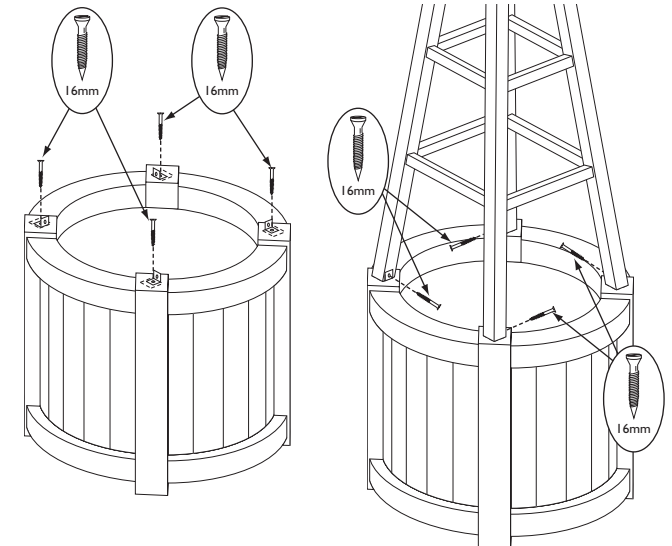

We constantly improve the quality of our products, occasionally the components may differ from the components shown and are only correct at time of printing. We reserve the right to change the specification of our products without prior notice.