

Assembly Instructions

Before assembly

- We recommend that time is taken to read the instructions before starting assembly, then follow the easy step by step guide. The instruction sheet is only a guide to the assembly. Certain items may not be shown to scale.
- Check all components prior to assembly
- This product should be assembled by no less than two people.
- Never attempt to erect the assembly in high winds.
- Drill components where indicated.
- Some of the components may have sharp edges wear protective work gloves while handling components.





Caution
This product contains glass. Wear protective work gloves while handling these components.

Dimensions:
Overall external:
 Height = 2745mm
 Width = 2650mm
 Depth = 2170mm
Footprint:
 Width = 2340mm
 Depth = 1870mm
Min. base area:
 Width = 2440mm
 Depth = 1970mm

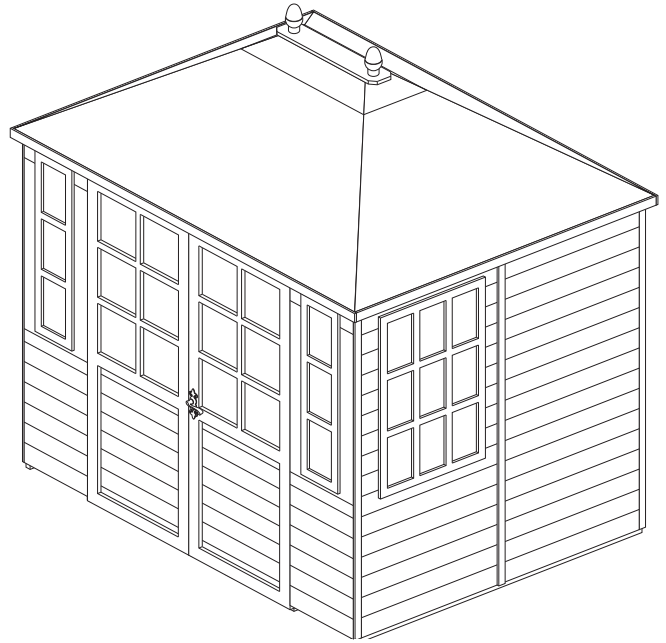

Recommended tools for assembly

- Power drill/screwdriver
- Cross head drill bit
- 3mm diameter drill bit
- 12mm diameter drill bit
- Hammer
- Sharp knife
- Spirit level
- Silicon sealant
- Step ladder
- Gloves

No.	Components	Qty.
1	Large floor panel	2
2	Small floor panel	1
3	Large wall panel	4
4	Small back panel	1
5	Side window panel	2
6	Front window panel	2
7	Side window frame	2
8	Front window frame	2
9	front header panel	2
10	Left-hand door	1
11	Right-hand door	1
12	Door header rail (29x35x1438mm)	1
13	Kick/header coverstrip (12x36x1438mm)	2
14	Left-hand triangular roof panel	4
15	Rectangular roof panel	2
16	Right-hand triangular roof panel	4
17	Roof centre block	1
18	Inside roof cover (615x140mm)	1
19	Long angled felt batten (right)	3
20	Long angle felt batten (left)	3
21	Short angle felt batten (right)	1
22	Short angle felt batten (left)	1
23	Roof felt Roll (10m)	1
24	Corner coverstrips (1920x48x12mm)	8
25	Short bargeboard (835x40x12mm)	2
26	Long bargeboard (1325x40x12mm)	6
27	Capping (645x140mm)	1
28	Acorn finials	2
29	Door glazing (284 x 306mm)	12
30	Front & side window glazing (193 x 304mm)	24
31	Door/window beading (15x15x308mm)	72
32	Door beading (15x5x258mm)	24
33	Front window beading (15x15x176mm)	12
34	Side window beading (15x15x167mm)	36

No.	Fixing Kit	Qty.
35	Hinges	12
36	Towerbolts	2
37	Door handle set	1
38	Metal handle bar	1
39	Door lock kit	1
40	Window stay	2
41	63mm screws	26
42	50mm screws	108
43	25mm screws	90
44	25mm black countersunk screws	20
45	25mm brass screws	4
46	20mm screws	8
47	19mm round head screws	8
48	40mm nails	62
49	25mm panel pins	288
50	10mm felt nails	200

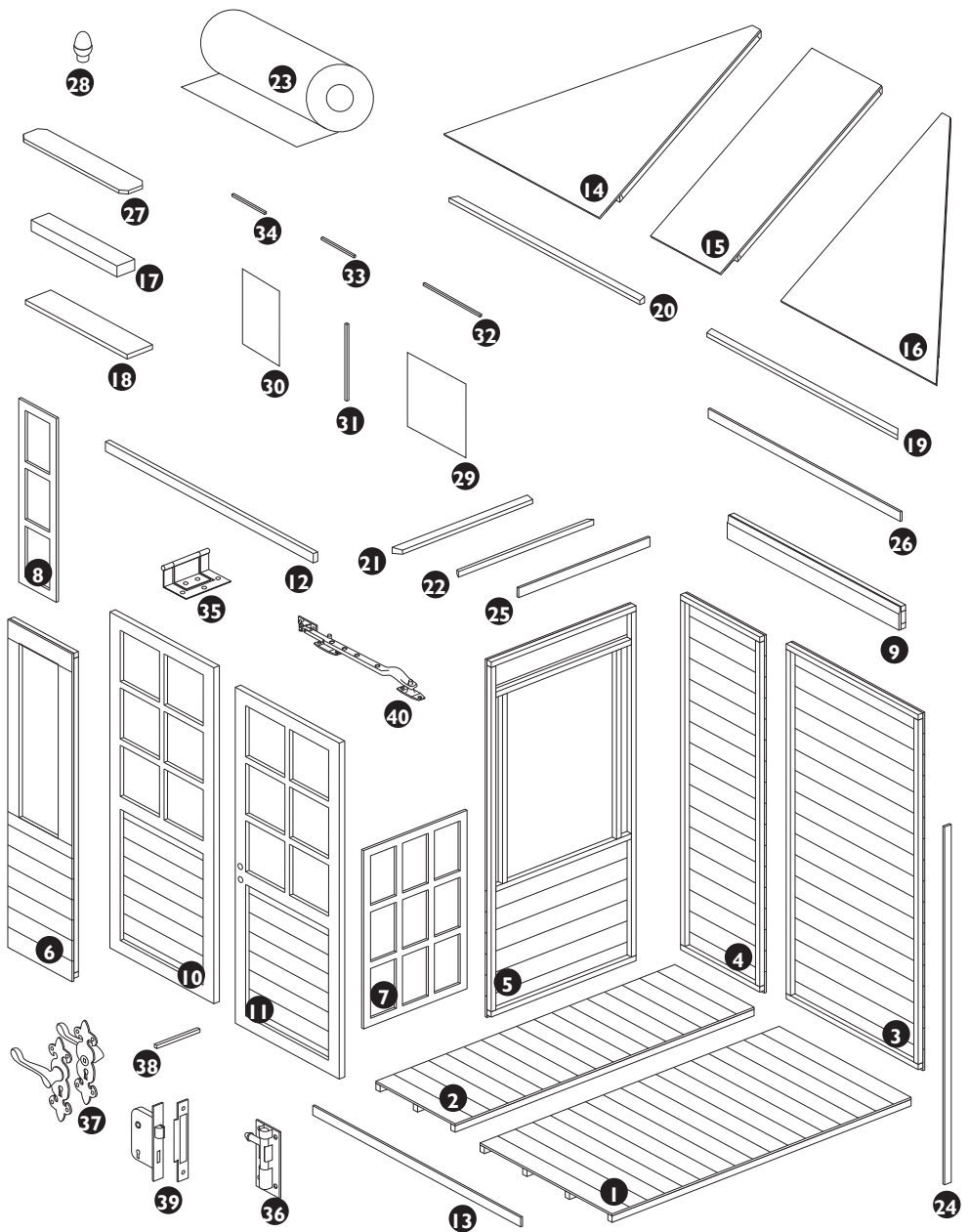

1. Floor section

Prepare a level area for the Summerhouse to sit. Lay the three floor panels upside down and secure them together using 5 x 50mm screws per join.

Important note

To "VALIDATE" the guarantee, adequate provision must be made to ensure ground contact is avoided and air is able to circulate underneath the building. Placing the building on a concrete pad or slab base is acceptable provided that the building is not allowed to sit in pooled water during wet conditions. If the building is to sit on soil or grass it **MUST** be erected on pressure treated wooden 50mm x 50mm or similar bearers (These are not supplied in the kit).

Rowlinson Garden Products recommend using pressure treated bearers with all buildings on any type of base.

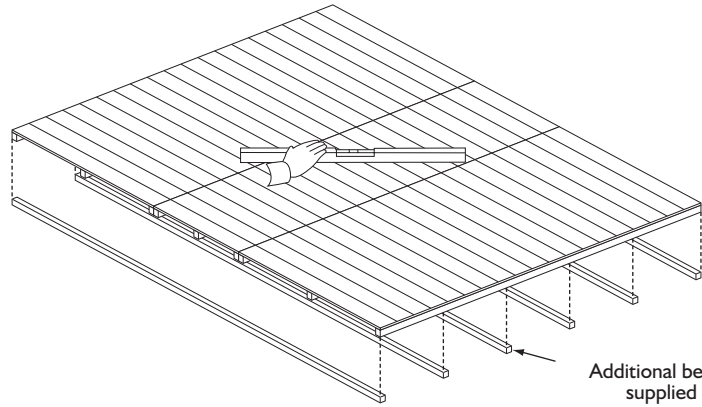
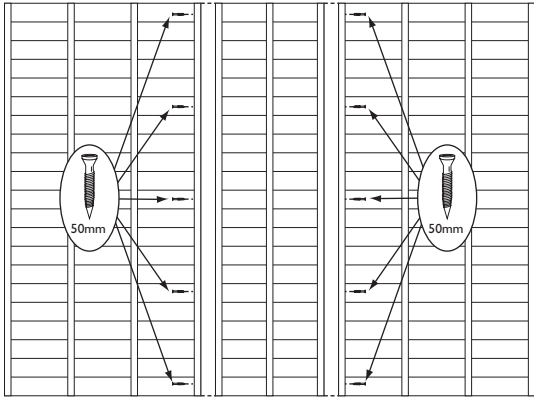

Additional bearers not supplied in kit

2. Opening windows

Fit the small tab of two hinges to the short edge of each window frame using 2 x 20mm screws per hinge. Lay the window panels on the floor, stand the hinge end of the window frame on the window opening, making sure it is centred at the top of the window opening. Open the hinges and secure them to the window panel frame using 5 x 25mm screws per hinge. On the inside of the window panel fit the window stay and its two posts using 6 x 25mm black screws as shown in the diagram.

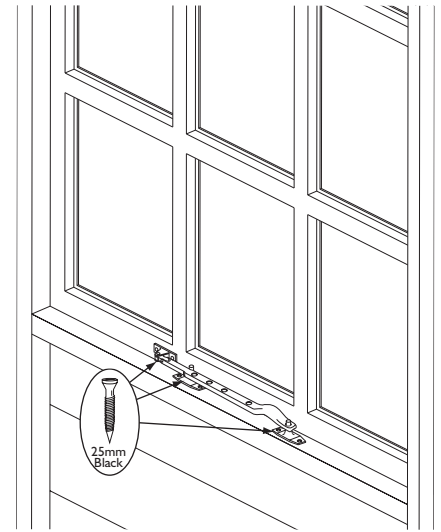
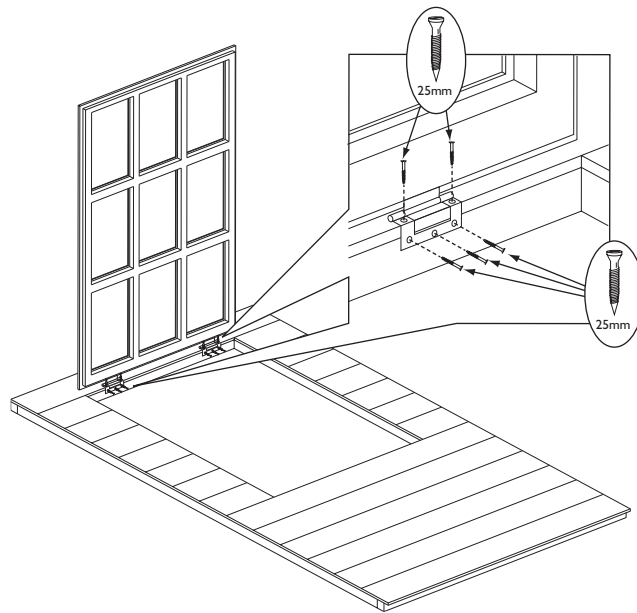
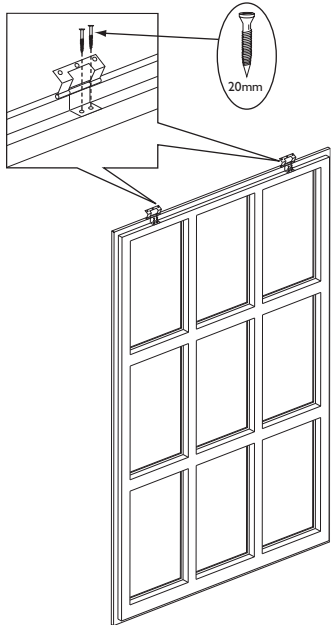

3. Fixed front windows

Position a front window frame into the opening on each front window panel. Drill four pilot holes on the inside edge of the frame and secure the frame in place using 4 x 50mm screws.

View from rear of panel

Position the front window frame into the front window panel opening.

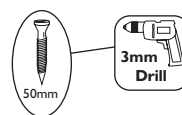
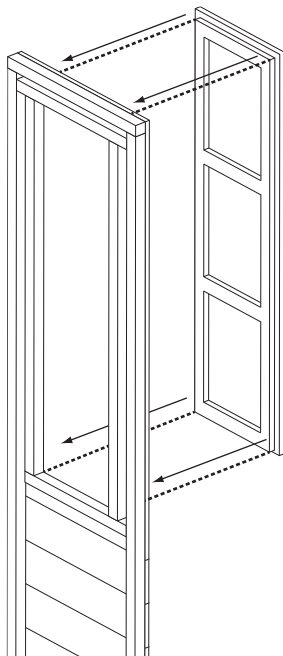

Drill four pilot holes on the inside of the frame as shown and secure the frame in place using 4 x 50mm screws.

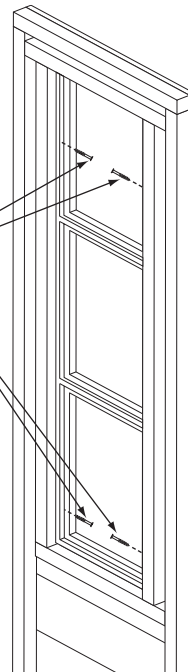

4. Glazing

Glazing the windows can be done once the building is assembled. However, it may be easier to install the glass whilst the panels are laid flat on the ground. Working on one panel at a time lay each door and window panel flat. Apply a very small bead of waterproof silicon sealant around each glazing rebate. Carefully place a window pane into each rebate. Secure each pane in place by pinning the window beading into position using 2 x 25mm panel pins per bead. Repeat for each pane of glass for all windows and doors.

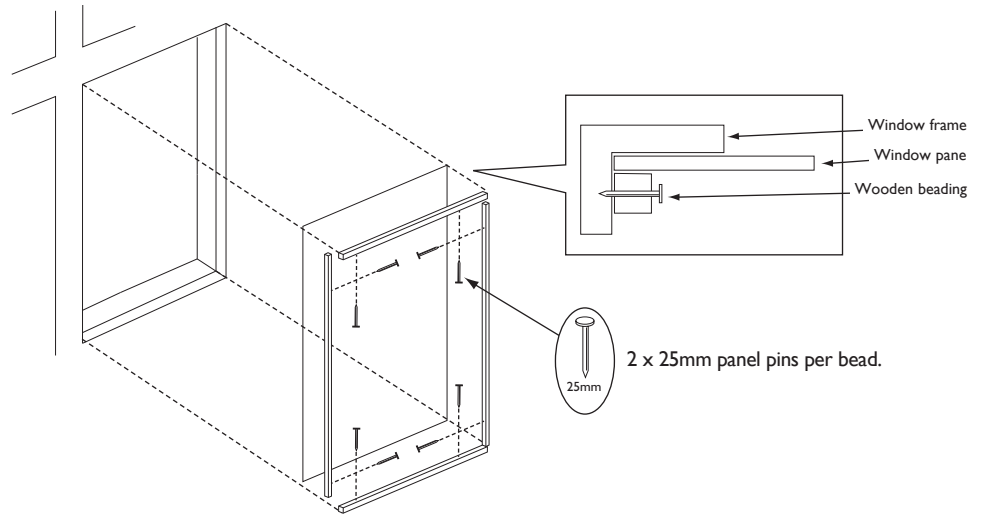

5. Wall panels

Position two large panels on the floor to create a back corner. Note how the panel frames sit on the floor with the panel cladding overhanging the floor edge. Ensure square and secure using 3 x 50mm screws, screw through the frame of the side wall panel into the frame of the back wall panel. Position the small back panel next to the first back panel, ensure level and secure them together using 3 x 50mm screws, screw through the frame of the second panel into the frame of the first. Continue adding the rest of the panels as shown in the diagrams using 3 x 50mm screws per join.

 It is recommended to drill pilot holes with a 3mm drill bit for each screws in this section.

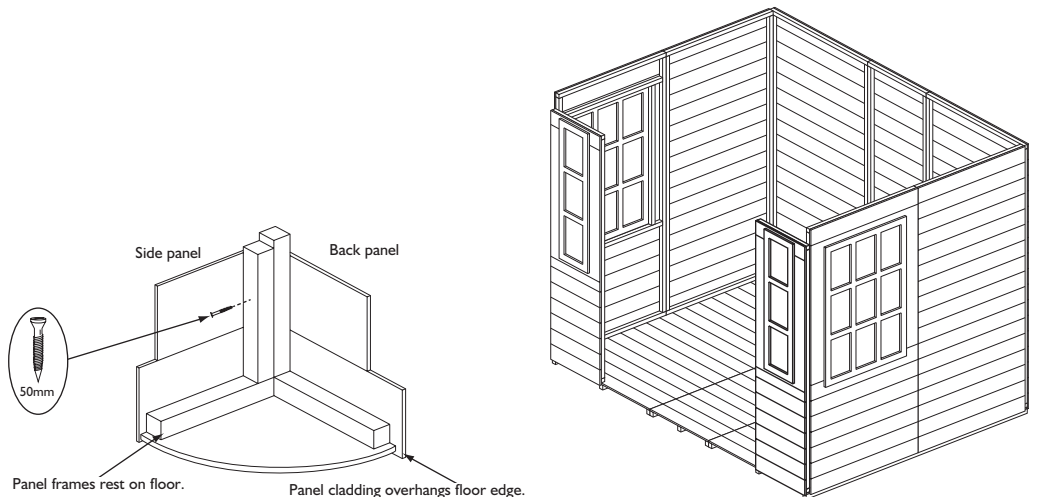
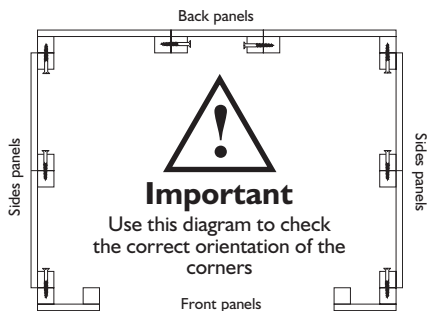
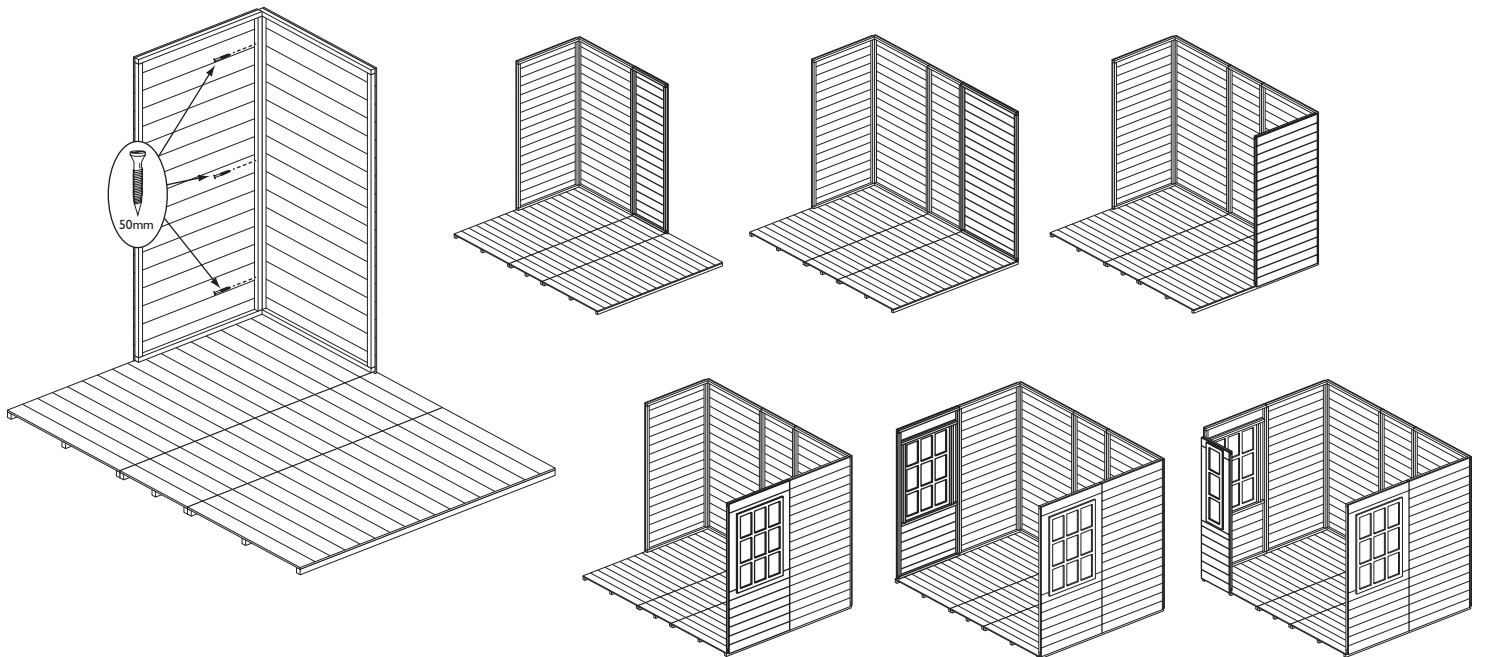

6. Header panel

Join together the two halves of the header panels using 2 x 50mm screws. Place the header panel on top of the two front panels, carefully interlocking the tongue and groove shiplap cladding. Ensure flush at each end and secure in place using 2 x 50mm screws into each front panel. Screw at an angle down through the bottom frame of the header panel into the top frame of the front panels.



Drill 3mm pilot holes for each screw in this section

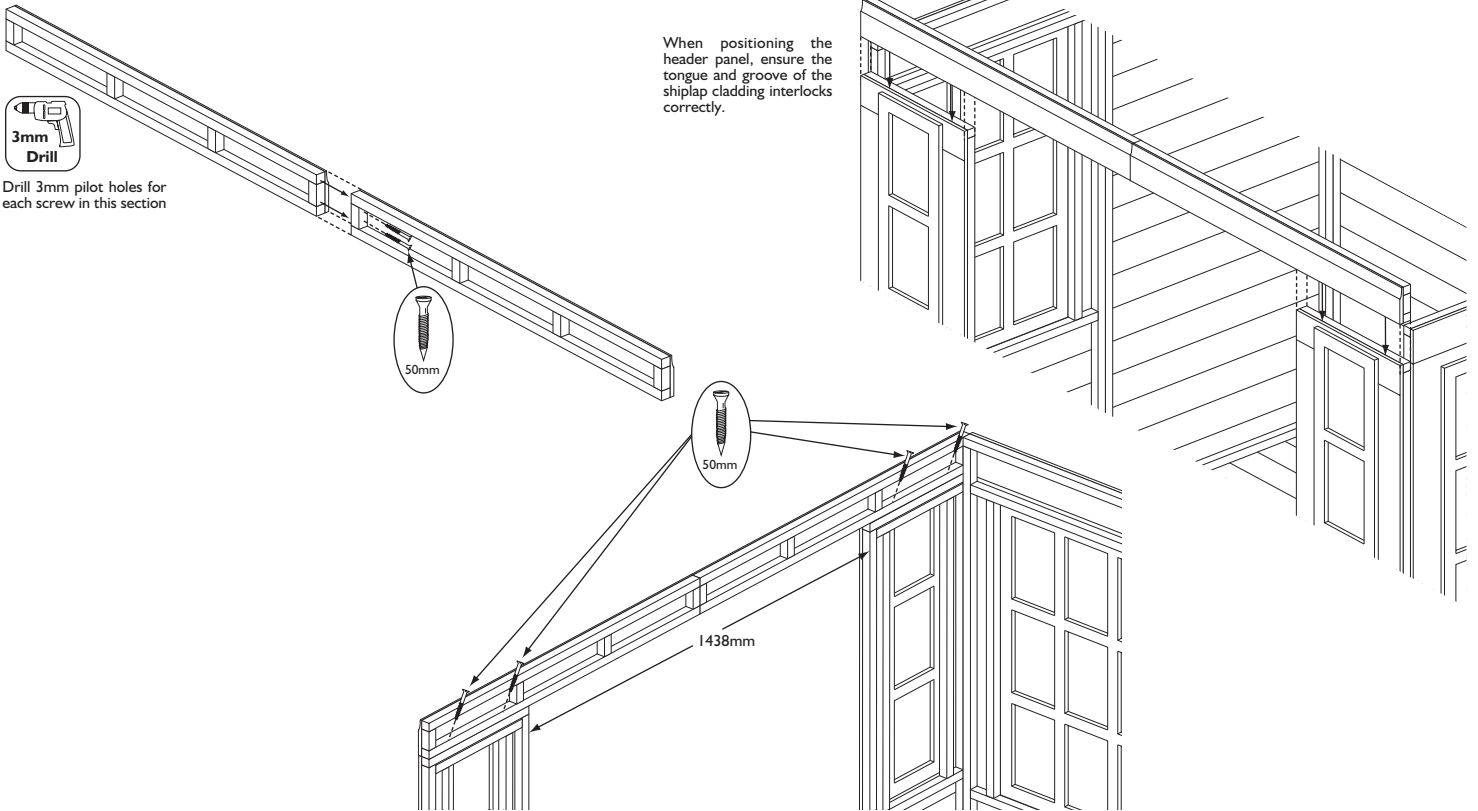

7. Door header rail and kick/header coverstrips

Position the door header rail between the two front panels up against the header panel frame. Nail to the front face of the header rail a header coverstrip using 4 x 40mm nails. Secure in place using 4 x 50mm screws. Centre the remaining kickstrip against the front edge of the floor and secure in place using 4 x 40mm nails.



Drill 3mm pilot holes for each screw in this section

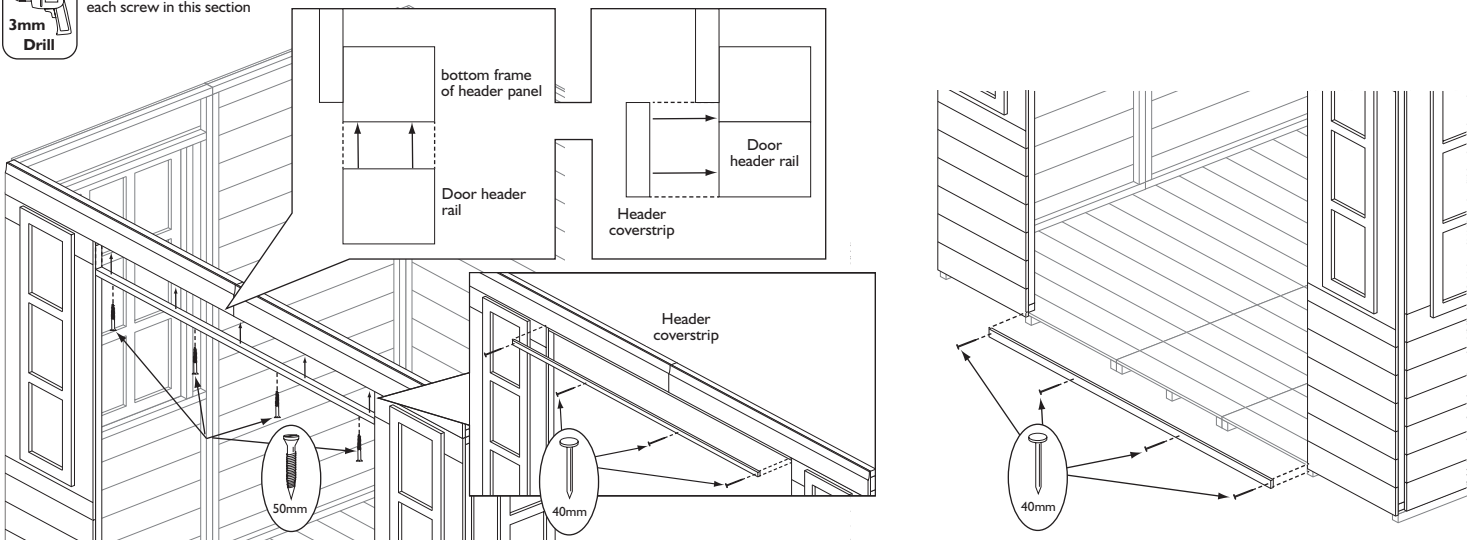

8. Securing the walls to the floor

Ensure the walls are sitting square on the floor. Secure each panel down using 2 x 63mm screws per panel, screwing through the panel framing and floor into the floor joists.

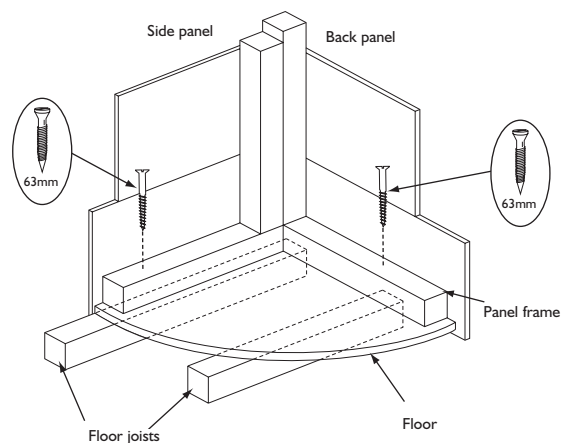
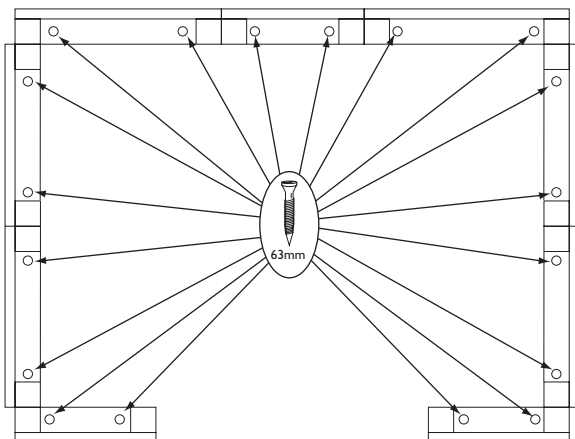

9. Roof panels

As shown below construct a side roof section using a right and a left triangular roof panel. Screw together using 2 x 50mm screws. Assemble a second side roof section in the same way. Create the front roof section using a right and left triangular roof panel and a rectangular roof panel using 4 x 50mm screws. Assemble a second section in the same way for the back.

Side roof sections.

Create two identical side sections, one for the left and the other for the right side of the summerhouse.

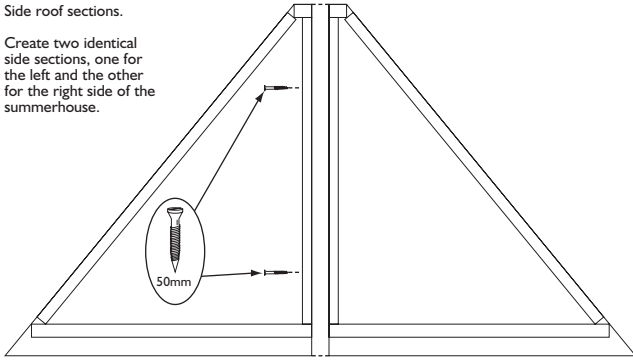

Front and back roof sections.

Create two identical sections one for the front and 1 for the back of the summerhouse.

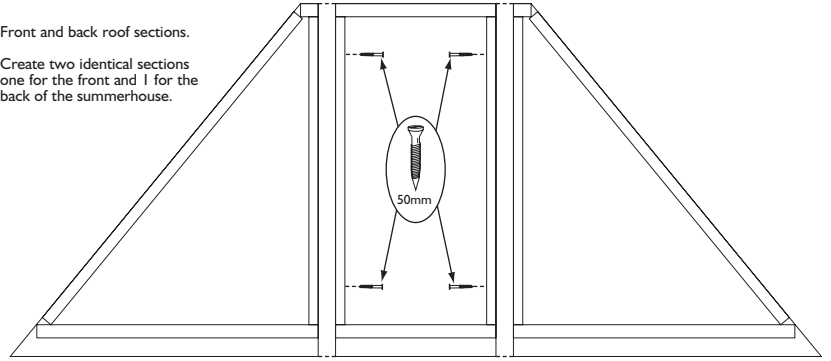

10. Roof

Have a person standing in the centre of the assembly to hold the panels while another person lifts them on. Hook the roof framing over the top frames of the wall panels. Evenly rest the panel edges against each other. Ensure the corner frames are square and level and secure using 2 x 50mm screws per corner as shown.

Cross section of wall

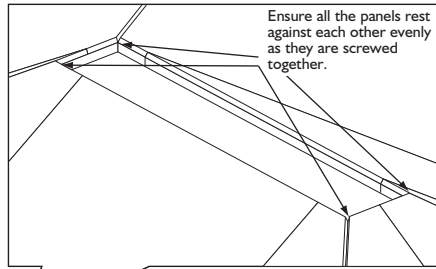
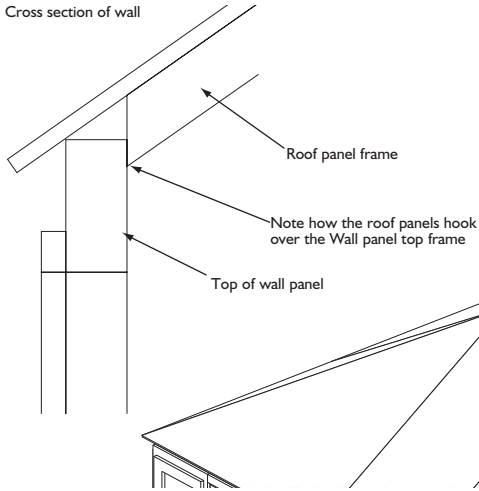

View of roof from inside the building

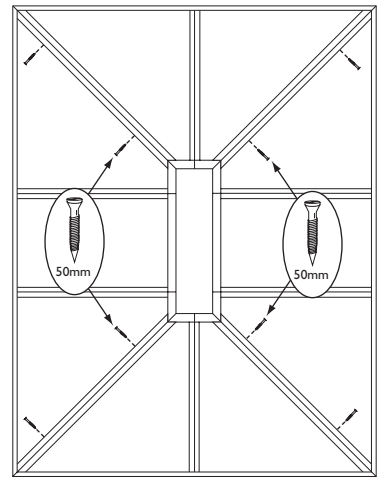

11. Roof centre block

Position the roof centre block in the hole in the middle, ensure it is flush with the roof panel framing and secure in place using 4 x 50mm screws. Screw through the frames of the rectangular roof panels into the centre block. Drill four holes in the inside roof cover, centre the cover over the centre roof block and secure in place using 4 x 50mm screws, screw through the drilled holes of the roof cover into the centre block.

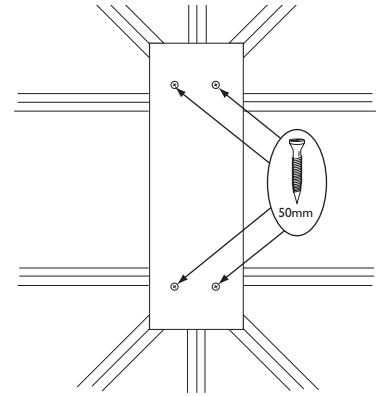
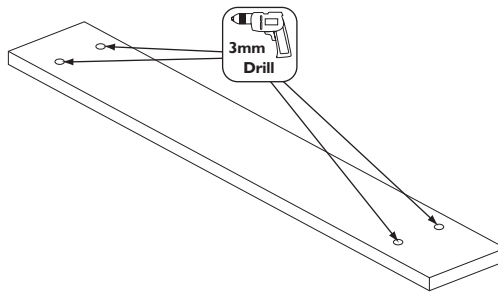
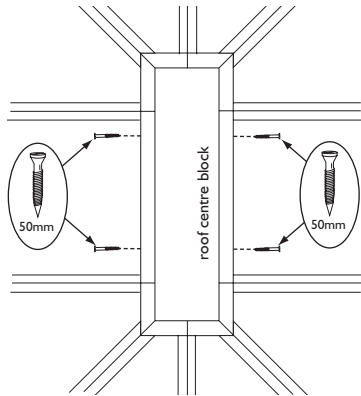

13. Secure roof to walls

Secure the roof to the walls using 8 x 50mm screws along each long edge and 6 x 50mm screws along each short edge. Screw through the roof panels into the top frame of the walls.

Cross section of wall

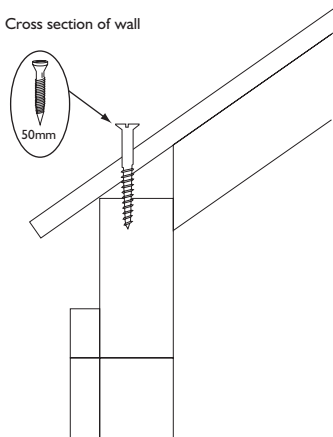

Overhead view

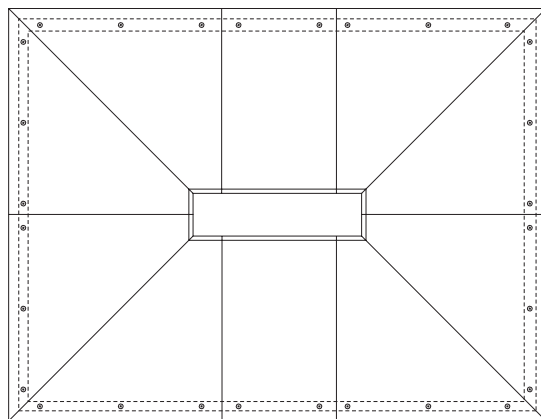

13. Doors

Fit four hinges to the long rebated edges of each door. Evenly space the hinges along the length of the doors leaving 150mm from the top and bottom of the door. Attach the small tab of each hinge using 2 x 25mm screws. Open the hinges and fit them around the door frame, adjust the door to the correct height and fix the hinges to the door frame using 3 x 25mm screws per hinge. Attach the tower bolts to the inside of the left door using 4 x 19mm roundhead screws per bolt. With the left door shut, mark where the bolts touch the floor and door header rail and Drill a 12mm hole for each bolt to fit in. To fit the door handle. Push the metal handle bar through the door latch mechanism. Fit a door handle to the metal handle bar on each side of the door and secure each handle in place using 4 x 25mm black screws. On the other door fit the lock catch plate using 2 x 25mm brass screws.

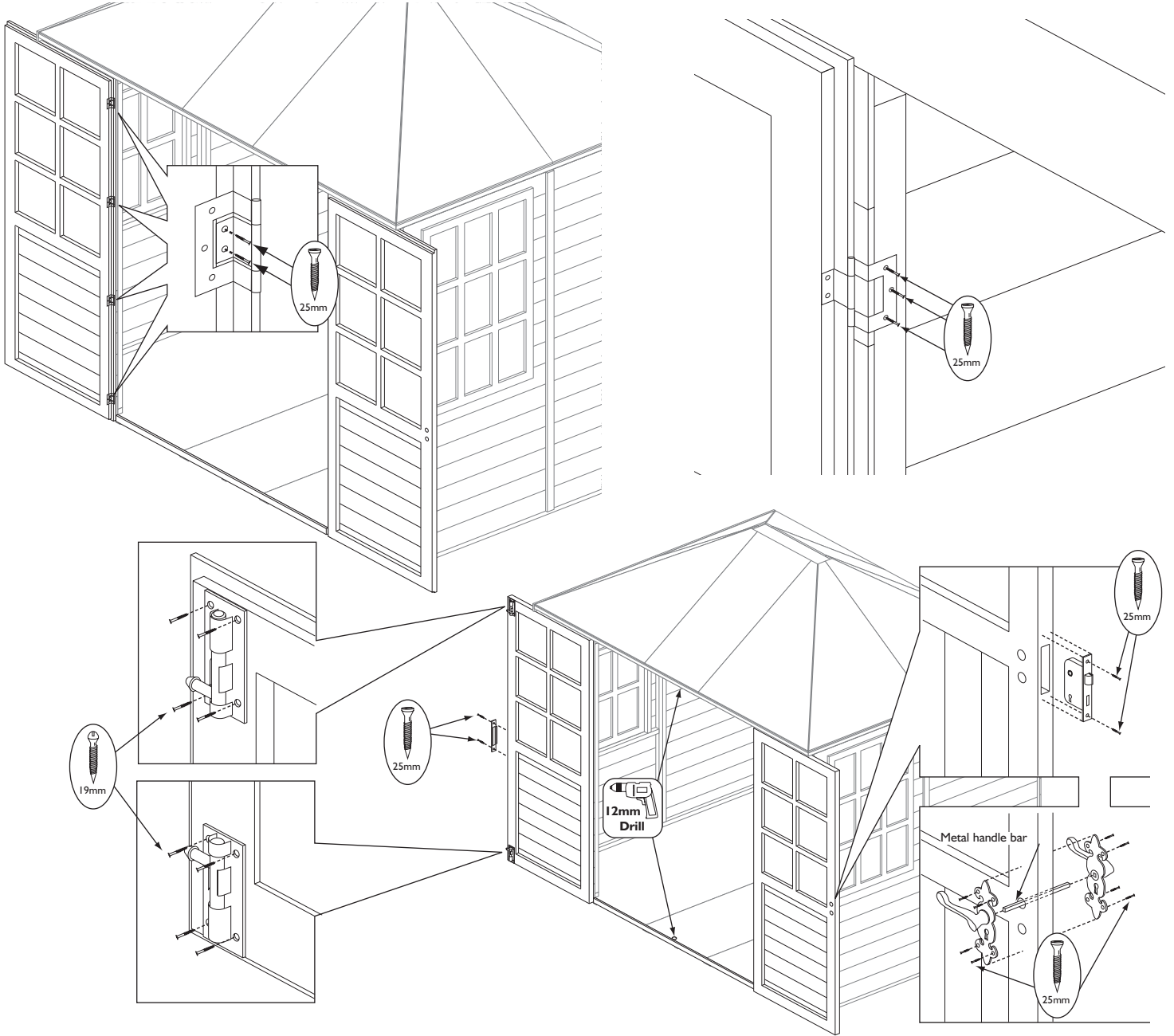

14. Felt battens

Around the edge of the roof position the angled edges of the felt batten against the underside of the roof panel, have the front face of the batten level with the end of the roof panel as shown. Secure in place using 4 x 25mm screws for the Long felt battens and 3 x 25mm screws for the short battens.

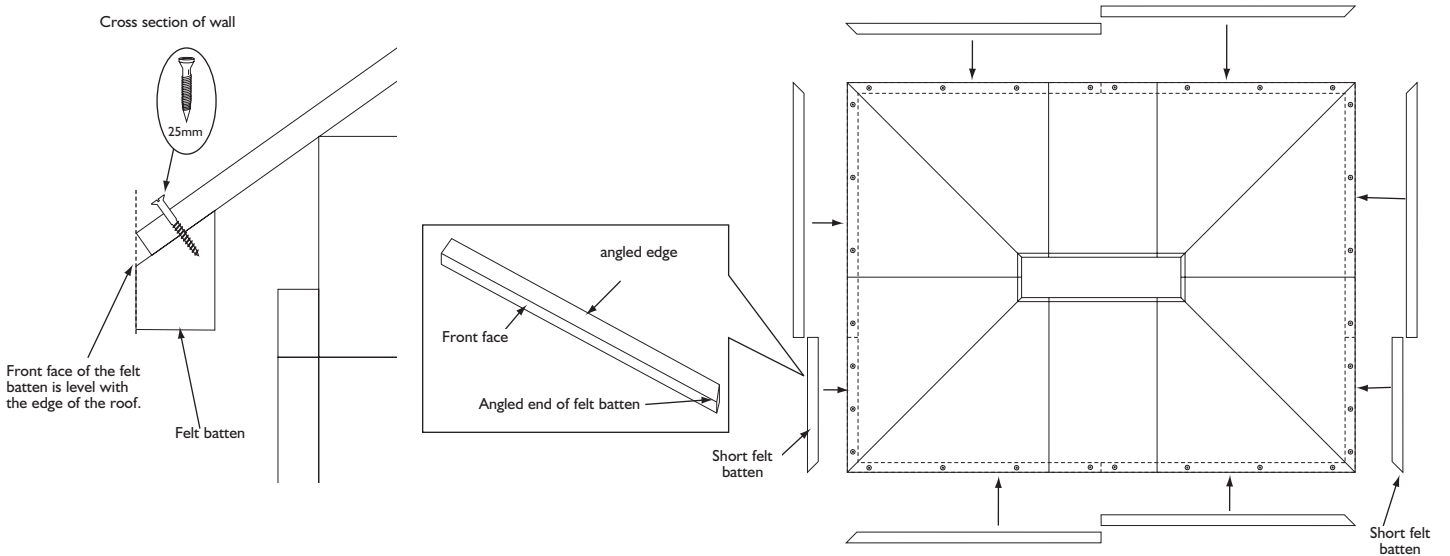

15. Roof Felt

Unroll the roll of felt, carefully measure and cut out the eight triangular shape pieces as shown in the diagram below.

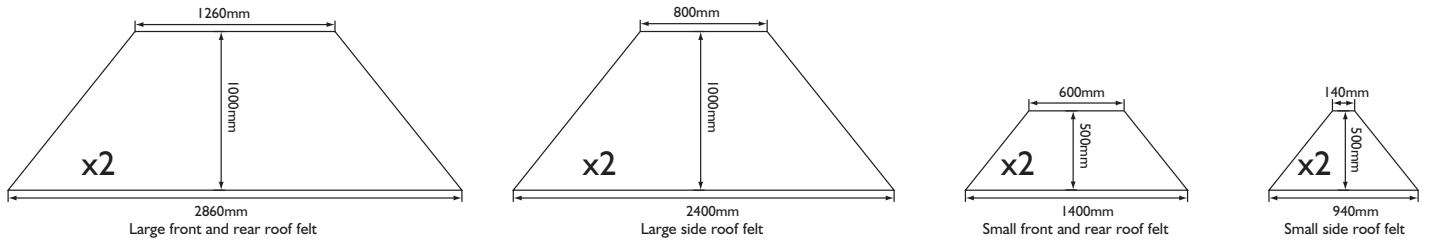

To get all 8 pieces from the 10m roll of felt use the guide below:

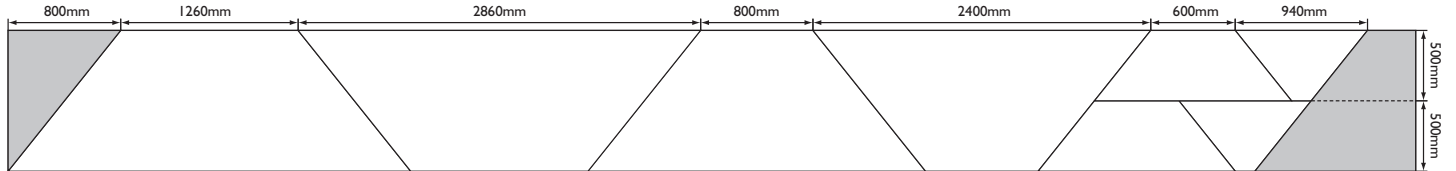

16. Side roof panel roofing felt

Position a large side roof felt (2400mm) centrally over the right-hand roof side. Fold the lower edge down to cover the felt batten. Secure the felt to the felt batten using 10 x 10mm felt nails evenly spaced. Tension the felt over the roof and secure along the upper edge using 3 x 10mm felt nail. Fold the front edge of the felt over the front roof panels and secure using 6 x 10mm felt nails. Repeat for the back edge of the felt. Position a small side roof felt (940mm) at the top of the right roof panels. Ensure that the lower edge overlaps the large felt and the upper edge overhangs the roof centre block. Once in position secure the lower edge with 5 x 10mm felt nails, tension the felt and secure at the top edge with 2 x 10mm felt nails. Fold the front and back edges over and secure each edge with 3 x 10mm felt nails. Repeat for the left-hand roof panel.

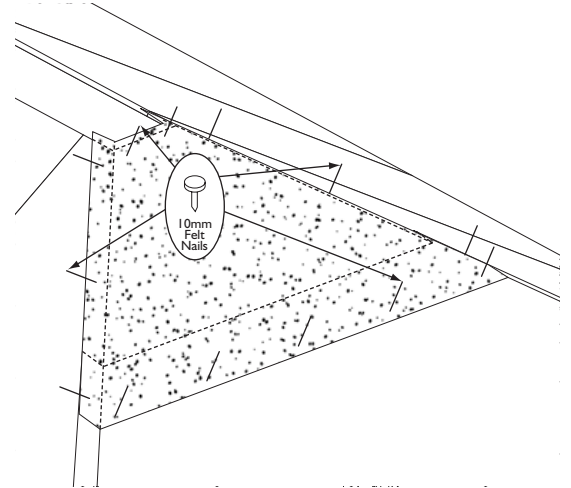
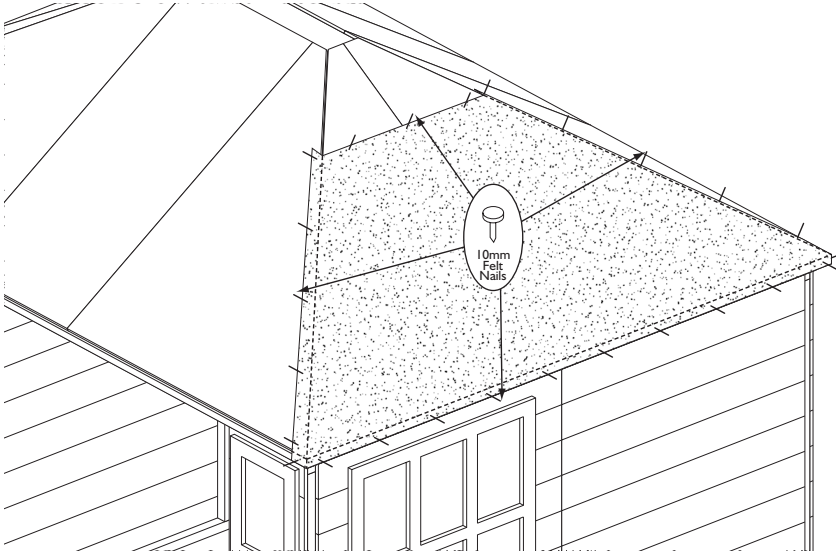

17. Front and back roof panel roofing felt

Position a large Front/back roof felt (2860mm) centrally over the front roof panel. Fold the lower edge down to cover the felt batten. Secure the felt to the felt batten using 14 x 10mm felt nails evenly spaced. Tension the felt over the roof and secure along the upper edge using 5 x 10mm felt nail. Fold the ends of the felt over the side roof panels and secure using 10 x 10mm felt nails. Position a small Front/back roof felt (1400mm) at the top of the front roof panel. Ensure that the lower edge overlaps the large felt and the upper edge overhangs the roof centre block. Once in position secure the Lower edge with 8 x 10mm felt nails, tension the felt and secure at the top edge with 4 x 10mm felt nails. Fold the ends of the felt over the side roof panels and secure each edge with 4 x 10mm felt nails. Repeat for the back roof panel.

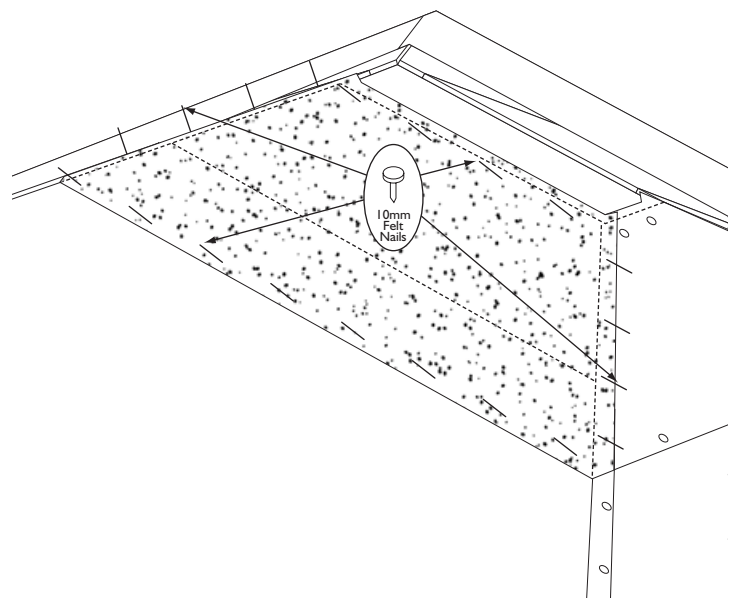
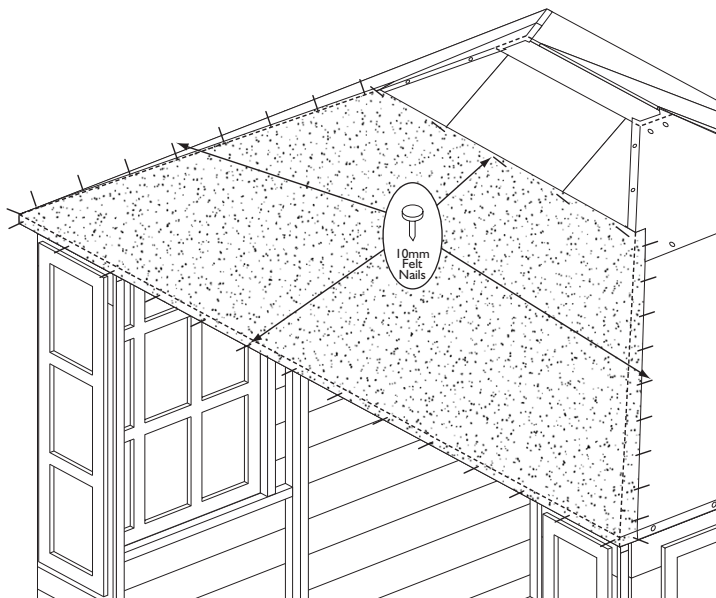

18. Coverstrips

Fit a coverstrip into each corner, attach using 3 x 40mm nails per strip. The four remaining coverstrips are to cover the joints between panels, two on the back and one on each side. Secure each strip using 3 x 40mm nails.

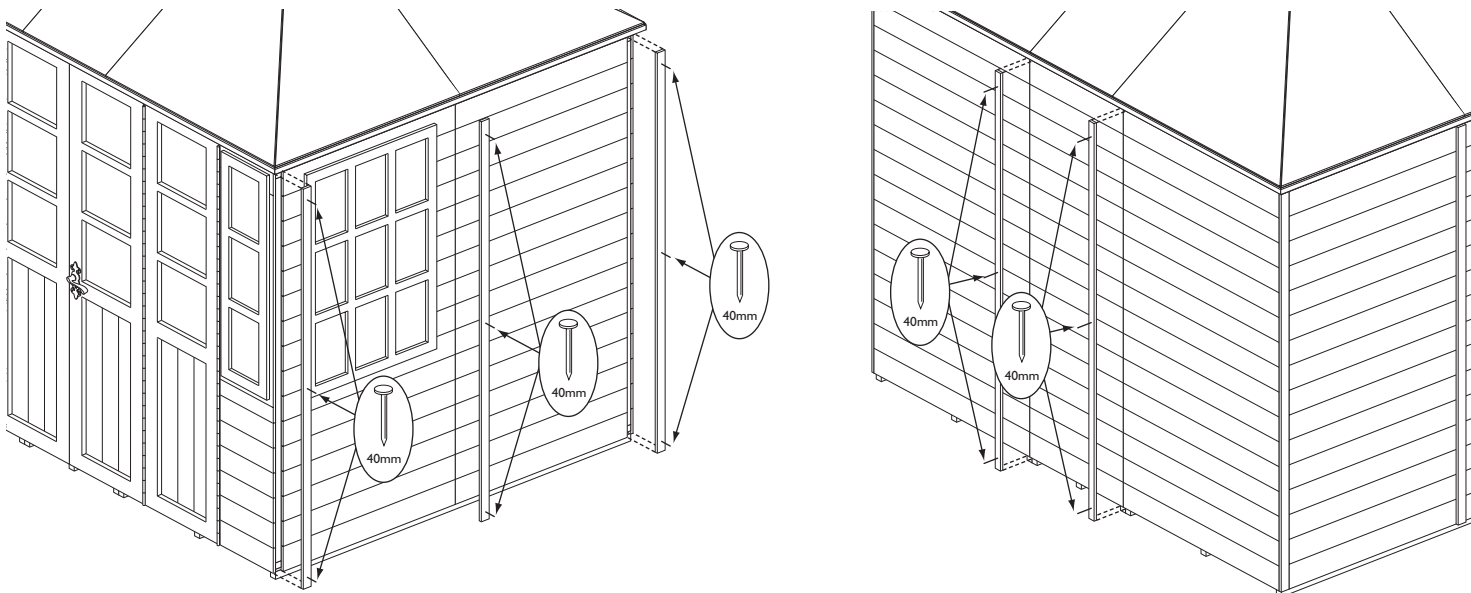

19. Bargeboards and finials

Attach the side bargeboards as shown using 4 x 40mm nails per board long board and 3 x 30mm nails per short board, ensure the top edges and the ends are flush with the roof line. With the sides in position secure the front and back barge boards using 4 x 40mm nails per board, Ensure their top edges are flush with the roof line and the ends level with the side bargeboards. The two finial centres are about 90mm from the ends of the capping piece. Drill two holes for each finial in the capping and secure the finials using 2 x 63mm screws per finial. Place the capping centrally over the centre of the roof and secure using 4 x 63mm screws. Screw through the capping into the centre roof block.

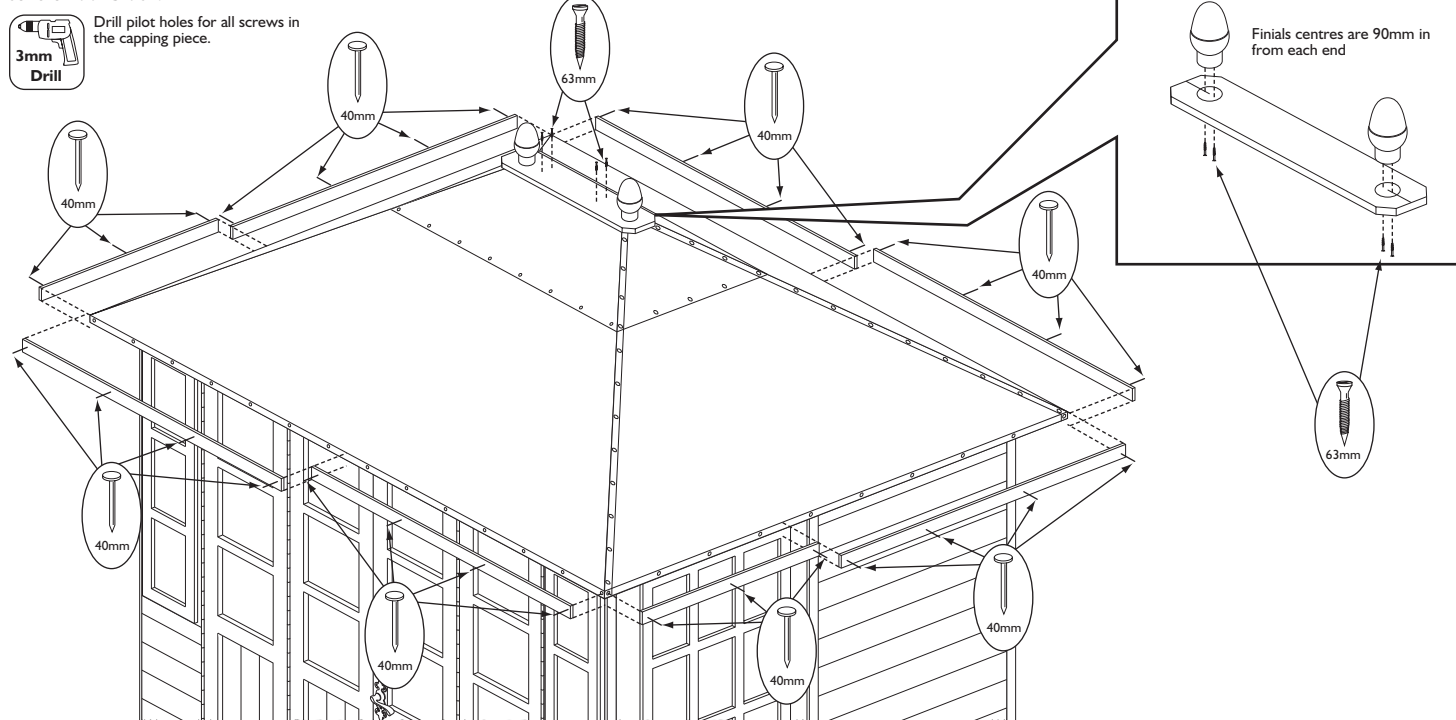

Important information

Shiplap buildings come ready stained but this is only a preparatory treatment. To **VALIDATE** the guarantee, the building must be properly treated with a recognised external wood preserver **WITHIN 3 MONTHS** of assembly and **RE-TREATED ANNUALLY** thereafter. Adequate provision must be made to ensure ground contact is avoided and air is able to circulate underneath the building.

Placing the building on a concrete pad or slab base is acceptable provided that the building is not allowed to sit in pooled water during wet conditions.

If the building is to sit on soil or grass it **MUST** be erected on pressure treated wooden 50mm x 50mm or similar bearers (**These are not supplied in the kit**).

Rowlinson Garden Products recommend using pressure treated bearers with all buildings on any type of base.

Timber Information.

As timber is a natural material, there are certain weather conditions that may affect the materials properties. In times of excessive dry spells the material may lose some of its internal moisture causing a certain degree of shrinkage on a panel and in periods of excessive rain there will be a certain amount of swelling throughout the wooden panels. This process can not be avoided. If you have problems with certain boards shrinking in dry spells try to decrease the amount of direct sunlight on the building or the amount of air passing over the building. During hot spells spray water directly onto the panels with the aid of a garden hose.

If in doubt of any aspect regarding the assembly, use or safety of your summerhouse please contact us :

Help Line: (Normal Office Hours) 01829 261 121

Email: support@rowgar.co.uk

ROWLINSON GARDEN PRODUCTS LIMITED
Green Lane
Wardle Nr. Nantwich
Cheshire
CW5 6BN
www.rowgar.co.uk

We constantly improve the quality of our products, occasionally the components may differ from the components shown and are only correct at time of printing. We reserve the right to change the specification of our products without prior notice.

2022 © Rowlinson Garden Products Ltd