

### Before assembly

- We recommend that time is taken to read the instructions before starting assembly, then follow the easy step by step guide. The instruction sheet is only a guide to the assembly. Certain items may not be shown to scale.
- Check all components prior to assembly
- This product should be assembled by no less than two people.
- Never attempt to erect the assembly in high winds.
- Drill components where indicated.



### Biocidal Products Regulation EU 528/2012

Wolmanit CX treated wood is a treated article that incorporates biocidal products: copper hydroxide carbonate/II/ and boric acid. They protect wood against fungal decay /rot/ and insect attack. Keep away from food, drink and animal feeding stuffs. Avoid breathing dust when cutting treated wood.

### Recommended tools for assembly

- Electric drill/screw driver
- Cross head screwdriver bit
- 3mm diameter drill bit
- Spirit level
- Step ladder

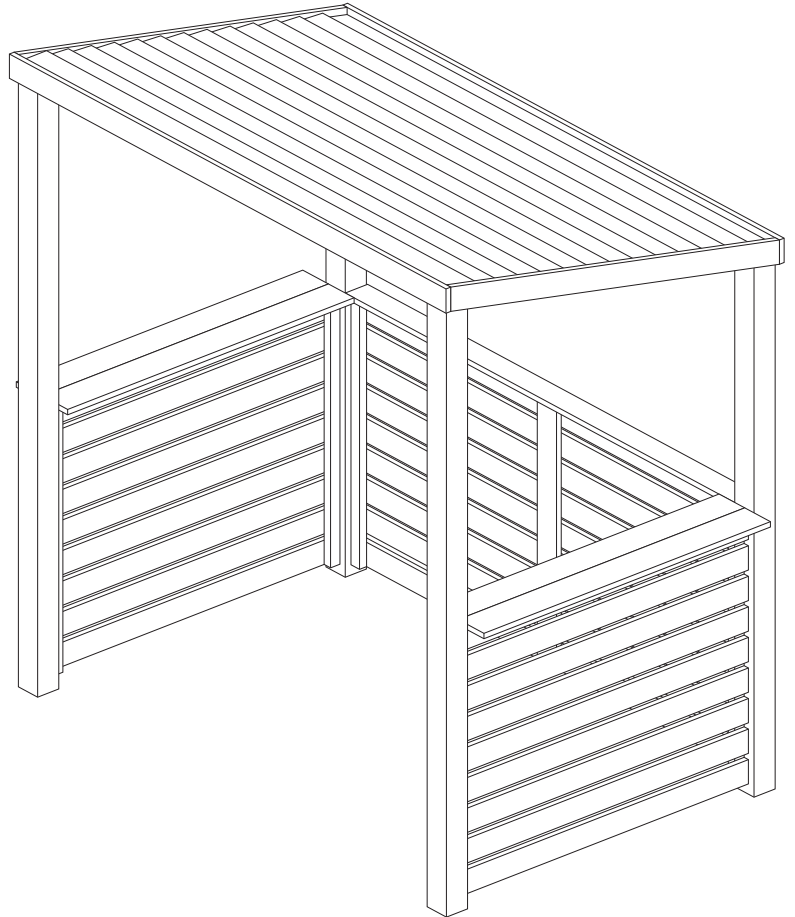

No.	Components	Qty.
1	Back leg (90x90x2000mm)	2
2	Front leg (90x90x2300mm)	2
3	Back panel	1
4	Side panel	2
5	Front/Rear roof frame (50x45x1820mm)	2
6	Roof rafter (50x45x1340mm)	4
7	Roof board (15x120x2000mm)	15
8	Side barge board (20x120x1470mm)	2
9	Front/Rear barge board (20x120x2045mm)	1
10	Side shelf (20x90x1220mm)	4
11	Shelf support blocks (40x30x200mm)	4

No.	Fixing kit	Qty.
12	Metal L-bracket	6
13	Roof board spacer tool	2
14	Panel height spacer (45x45x150mm)	2
15	100mm screws	20
16	70mm screws	18
17	50mm screws	84
18	20mm screws	24

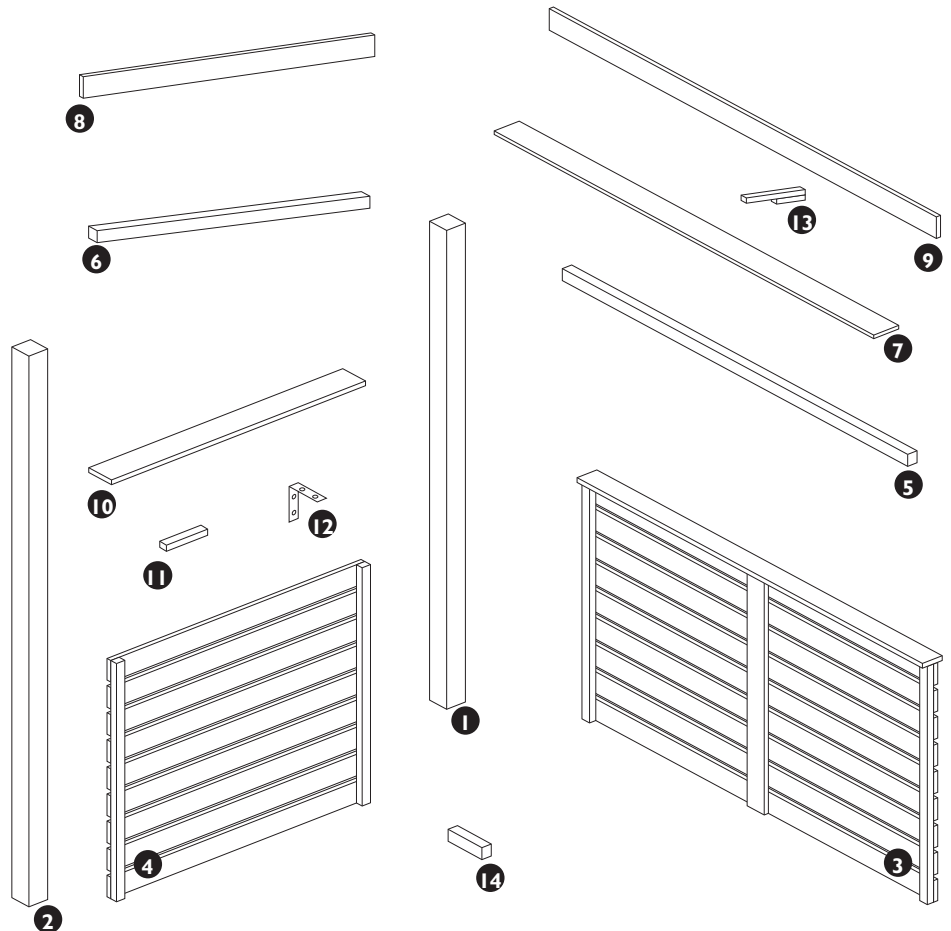

## 1. Legs, back and side panels

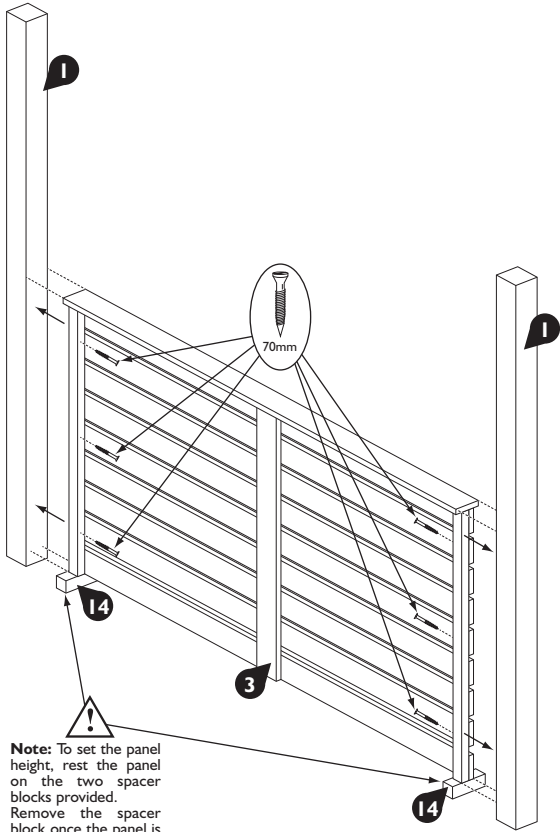

**Note:** To set the panel height, rest the panel on the two spacer blocks provided. Remove the spacer block once the panel is secure to the legs.

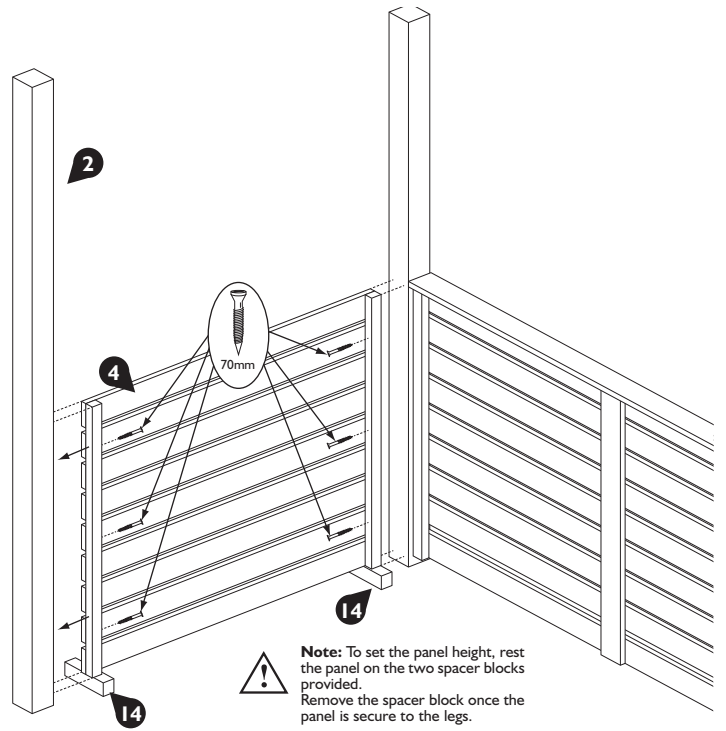

**Note:** To set the panel height, rest the panel on the two spacer blocks provided. Remove the spacer block once the panel is secure to the legs.

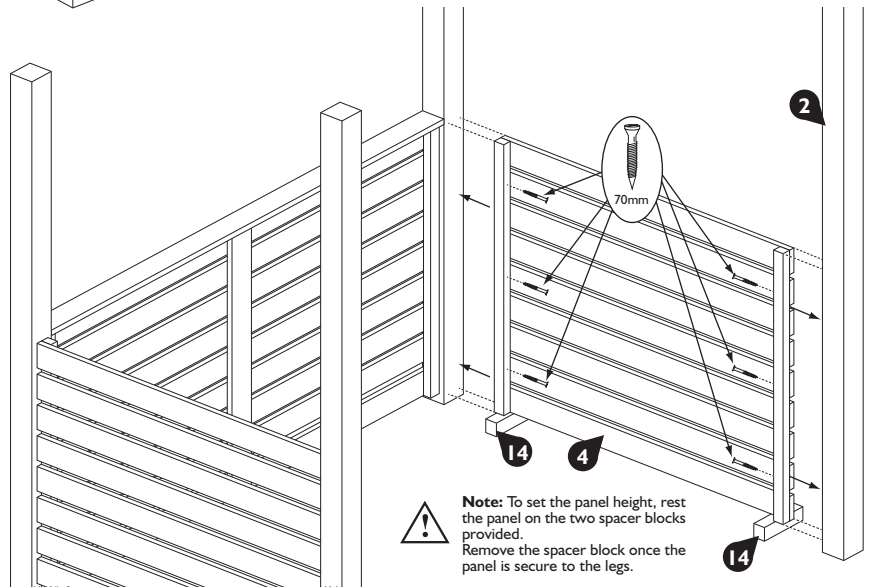

**Note:** To set the panel height, rest the panel on the two spacer blocks provided. Remove the spacer block once the panel is secure to the legs.

## 2. Outer shelf support blocks

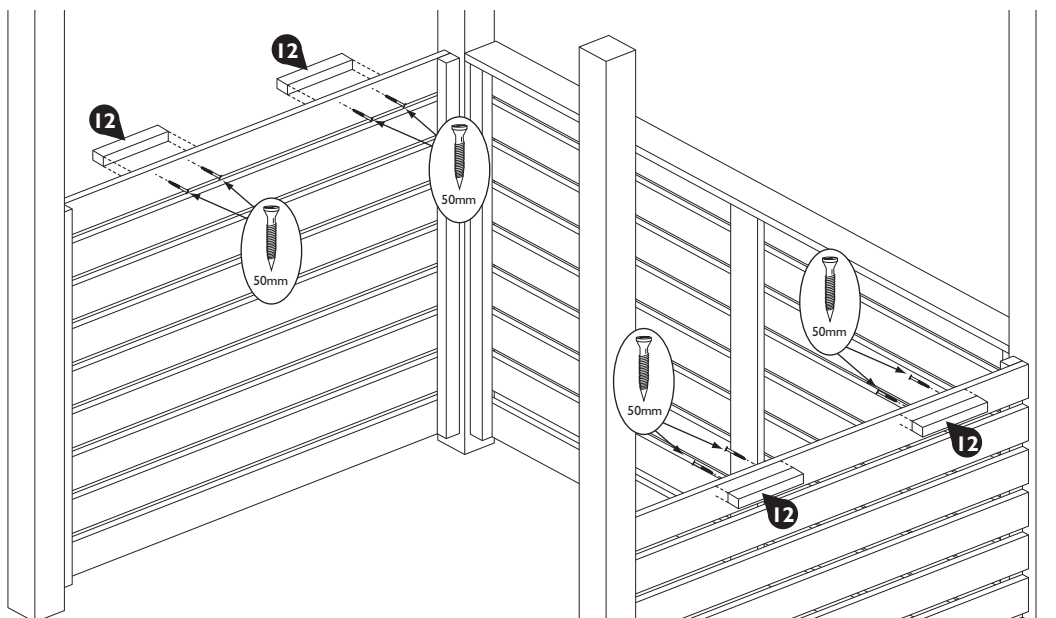

### 3. Side shelves

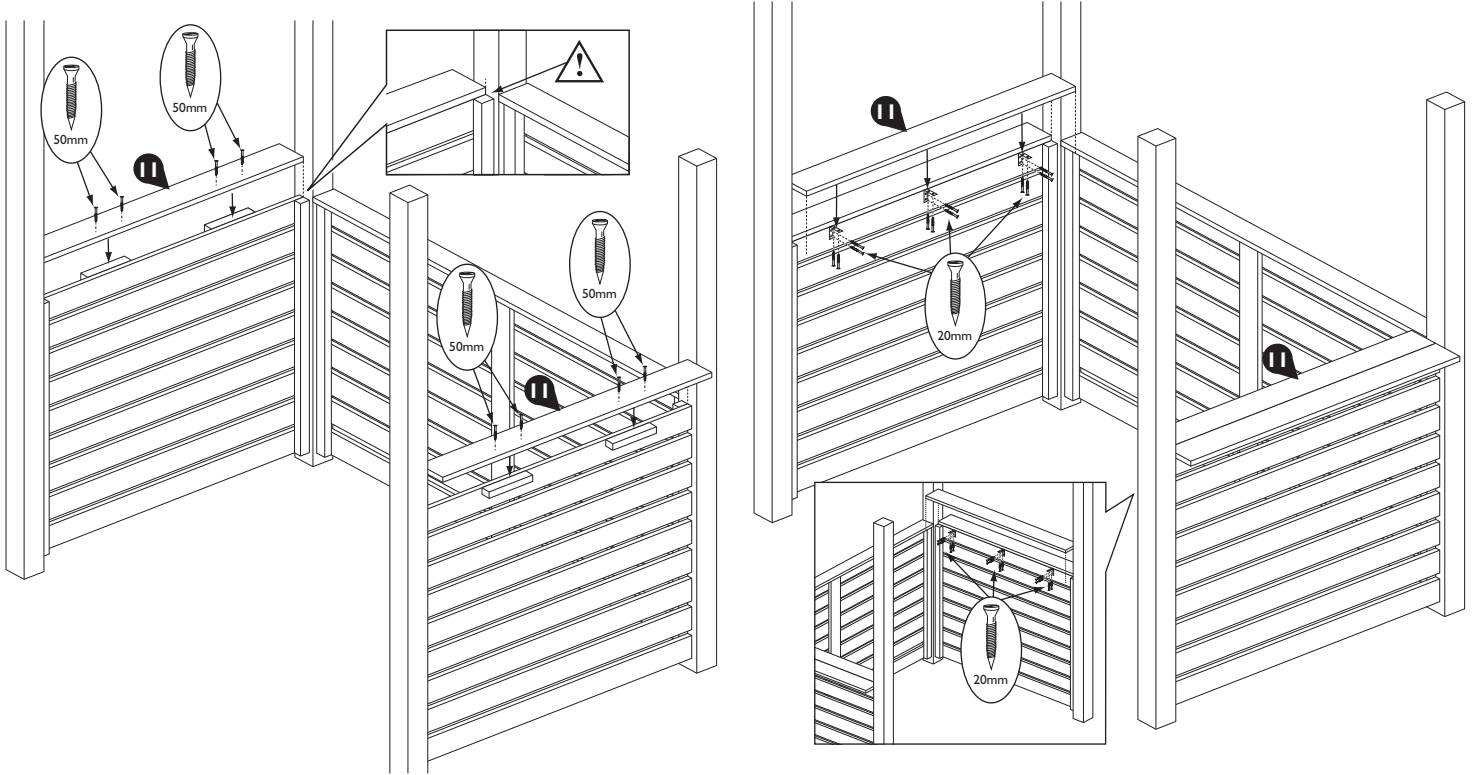

### 4. Roof frame

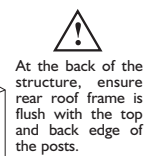
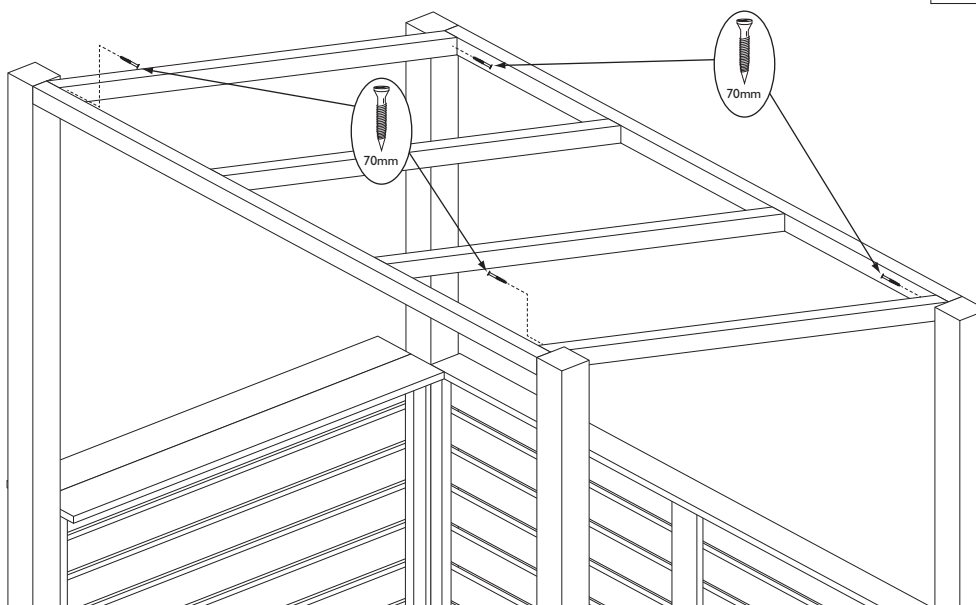
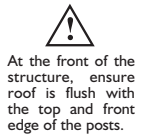
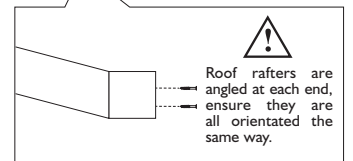
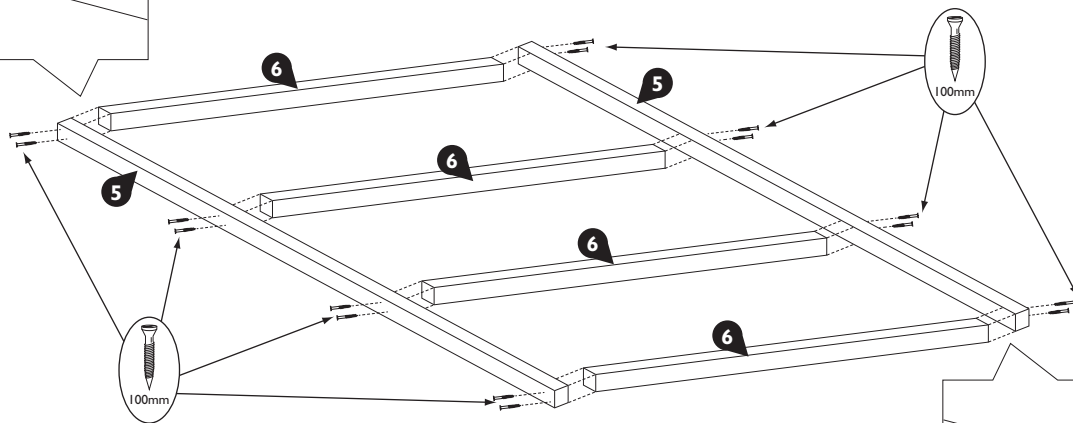
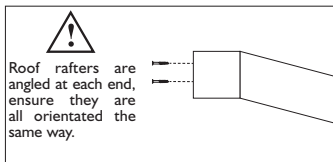

## 5. Roof Boards

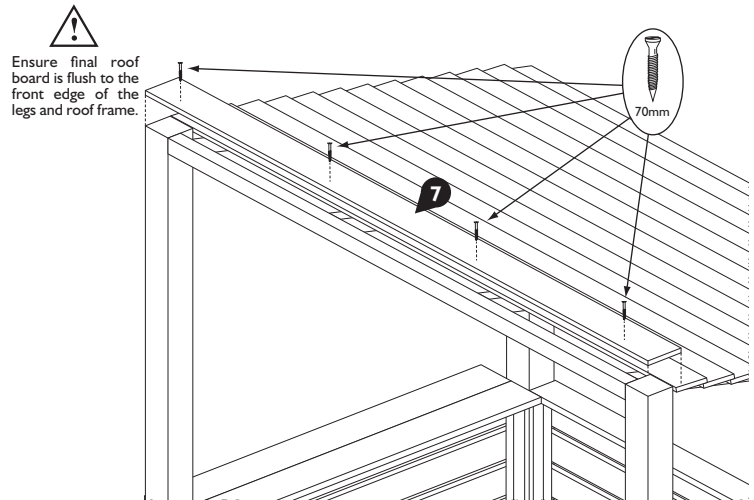
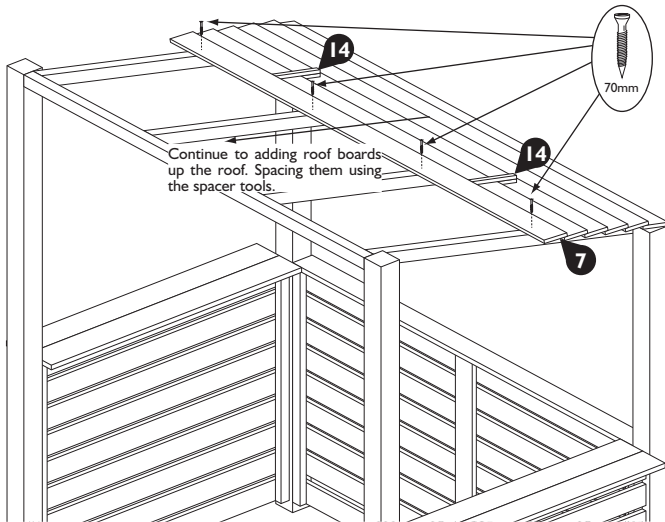
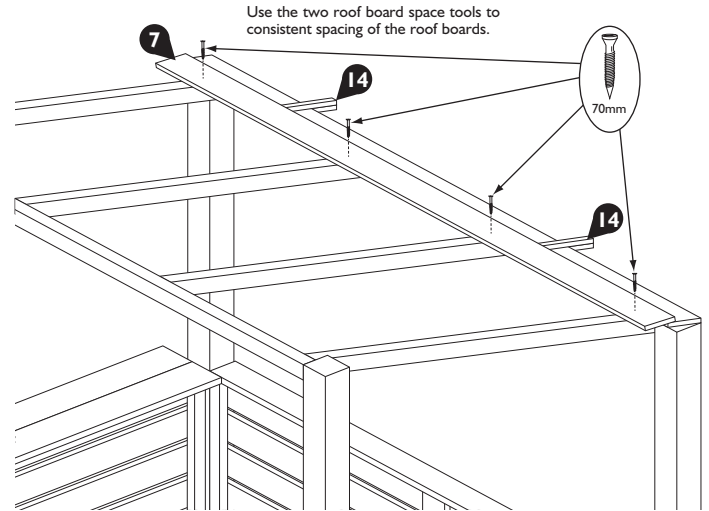
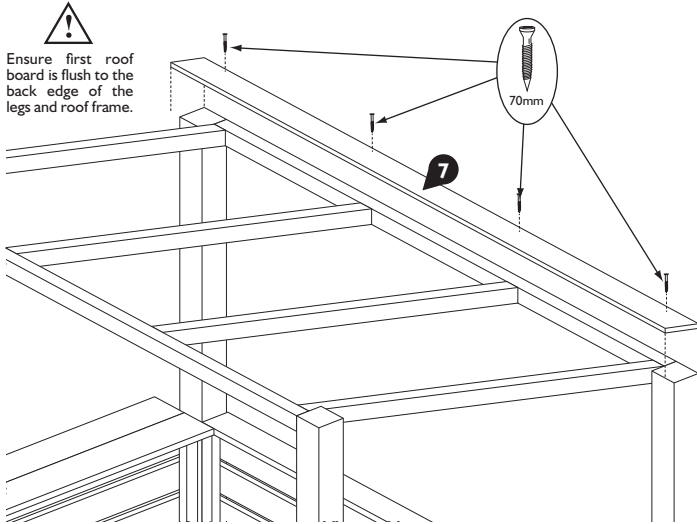

## 6. Barge Boards

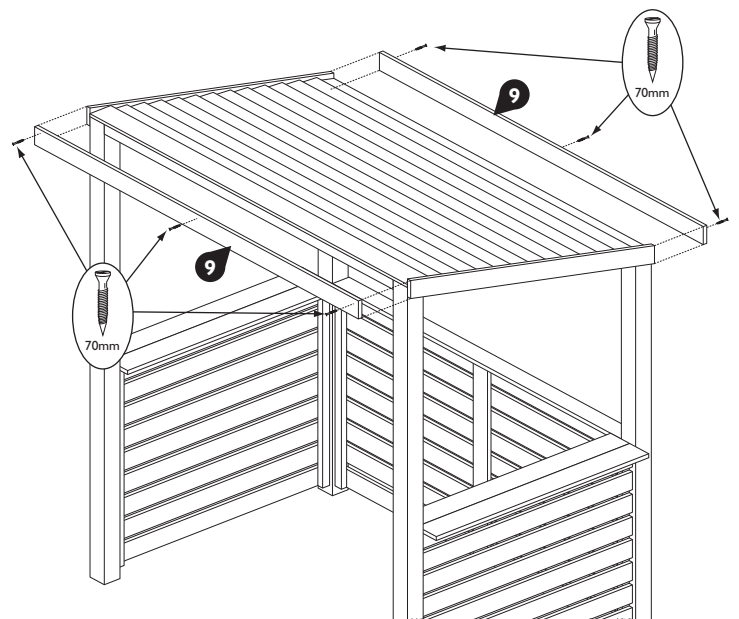
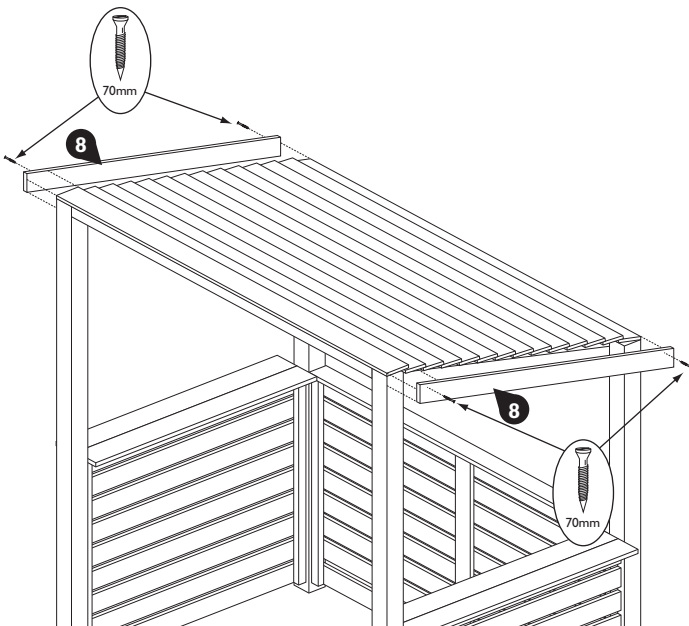

### Important information - retain for future reference

If in doubt of any aspect regarding the assembly, use or safety of your garden building please contact us:

**Help Line: (Normal Office Hours) 01829 261 121**

**Email: [support@rowgar.co.uk](mailto:support@rowgar.co.uk)**

ROWLINSON GARDEN PRODUCTS LIMITED  
Green Lane  
Wardle Nr. Nantwich  
Cheshire  
CW5 6BN  
[www.rowgar.co.uk](http://www.rowgar.co.uk)

We constantly improve the quality of our products, occasionally the components may differ from the components shown and are only correct at time of printing. We reserve the right to change the specification of our products without prior notice.

**2022 © Rowlinson Garden Products Ltd**